

Chapter 3: Processes

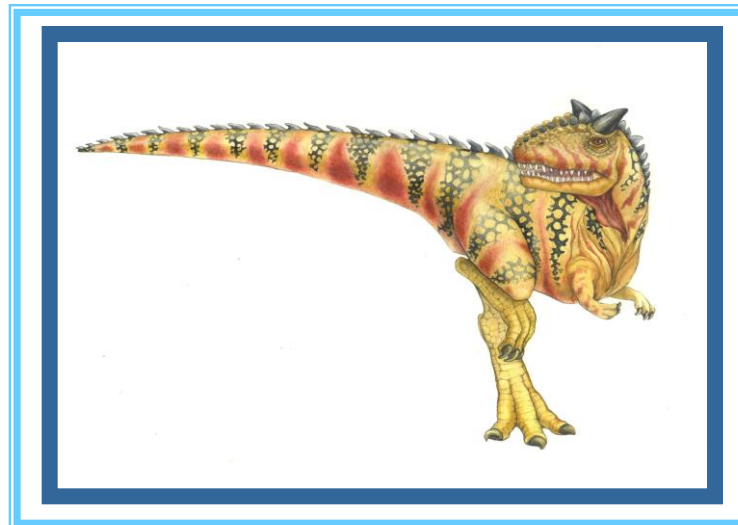

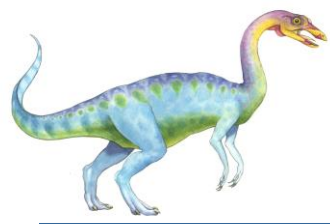

Chapter 3: Processes

- Process Concept
- Process Scheduling
- Operations on Processes
- Interprocess Communication
- Examples of IPC Systems
- Communication in Client-Server Systems



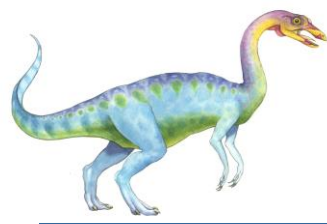

Objectives

- To introduce the notion of a process -- a program in execution, which forms the basis of all computation
- To describe the various features of processes, including scheduling, creation and termination, and communication
- To describe communication in client-server systems



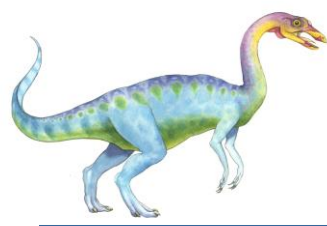

Process Concept

- An operating system executes a variety of programs:
 - Batch system – jobs
 - Time-shared systems – user programs or tasks

- Textbook uses the terms *job* and *process* almost interchangeably

- Process – a program in execution; process execution must progress in sequential fashion

- A process includes:
 - program counter
 - stack
 - data section



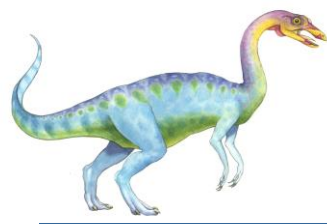

The Process

- Multiple parts
 - The program code, also called **text section**
 - Current activity including **program counter**, processor registers
 - **Stack** containing temporary data
 - ▶ Function parameters, return addresses, local variables
 - **Data section** containing global variables
 - **Heap** containing memory dynamically allocated during run time
- Program is passive entity, process is active
 - Program becomes process when executable file loaded into memory
- Execution of program started via GUI mouse clicks, command line entry of its name, etc
- One program can be several processes
 - Consider multiple users executing the same program





Process in Memory

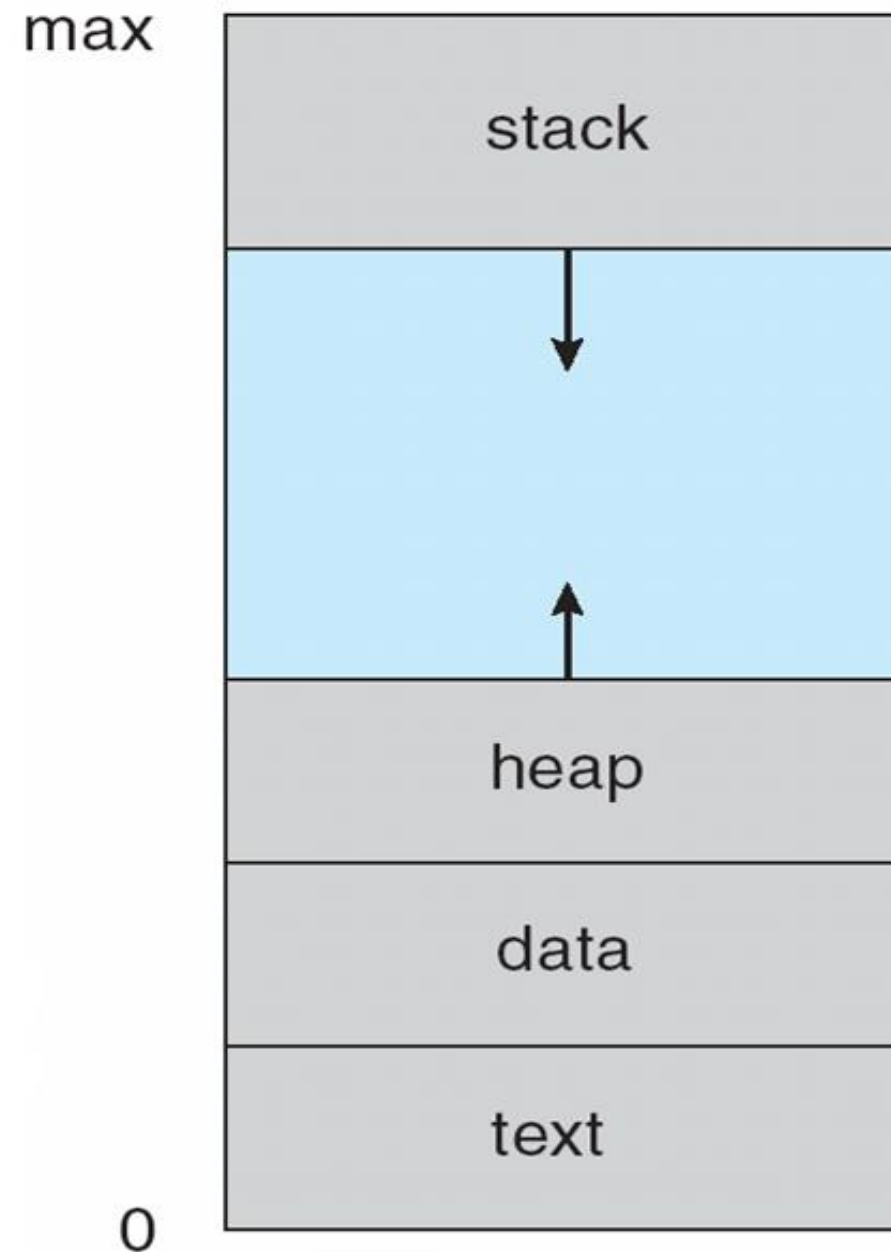

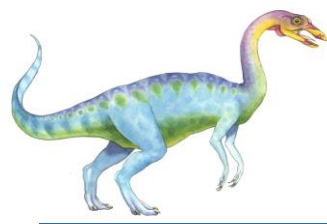

Process State

- As a process executes, it changes *state*
 - **new**: The process is being created
 - **running**: Instructions are being executed
 - **waiting**: The process is waiting for some event to occur
 - **ready**: The process is waiting to be assigned to a processor
 - **terminated**: The process has finished execution





Diagram of Process State

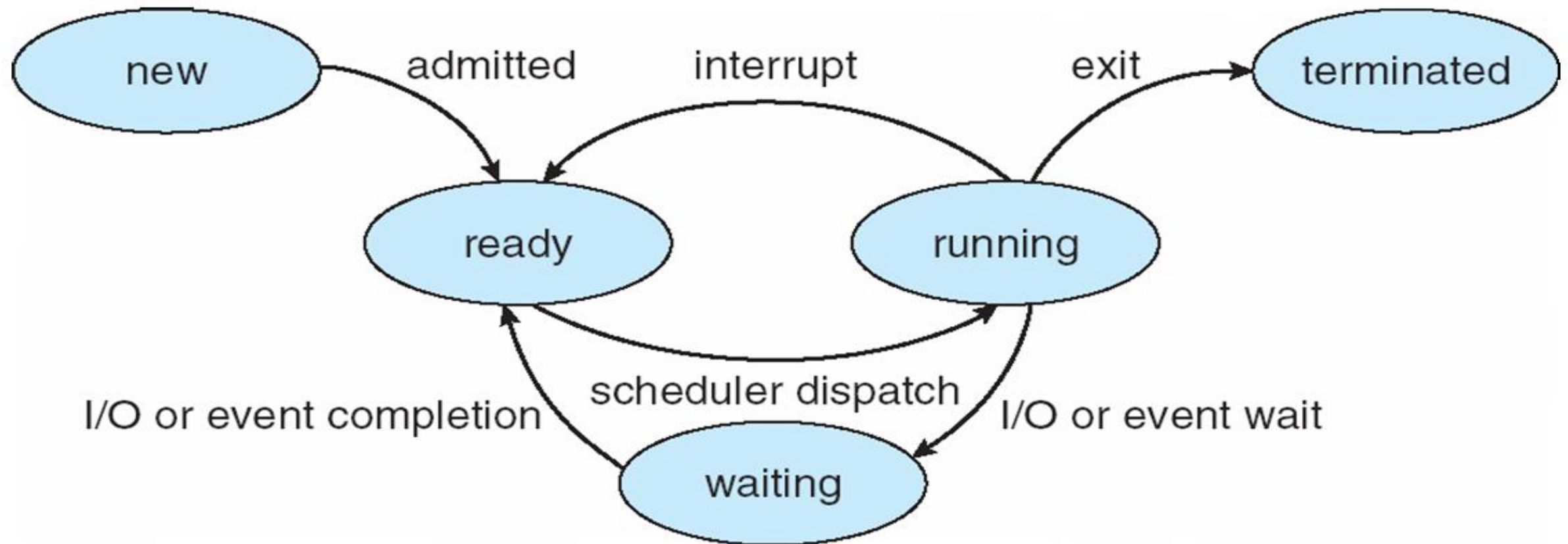



Process Control Block (PCB)

Information associated with each process

- Process state
- Program counter
- CPU registers
- CPU scheduling information
- Memory-management information
- Accounting information
- I/O status information



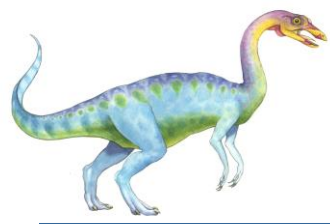

Process Control Block (PCB)

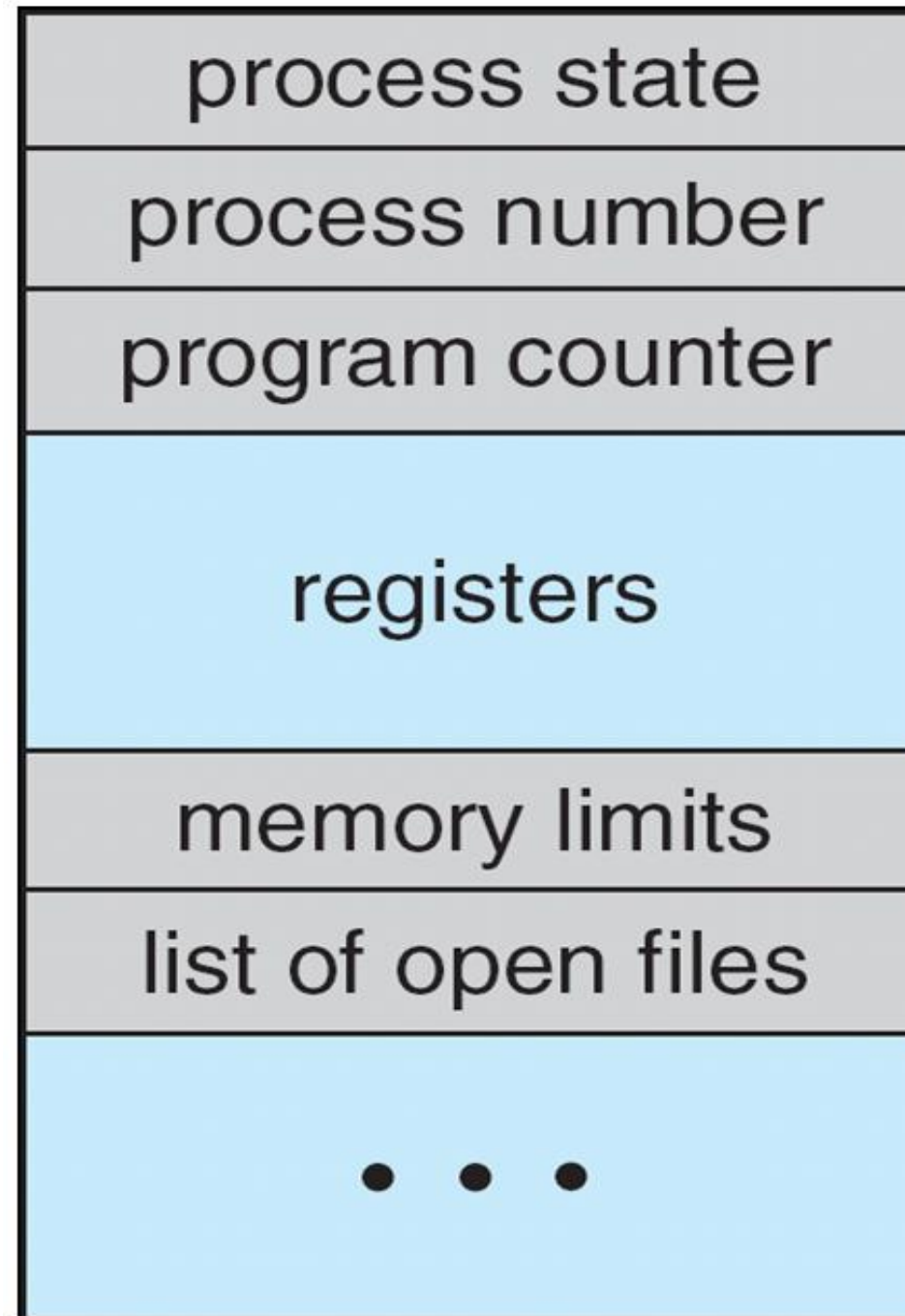



CPU Switch From Process to Process

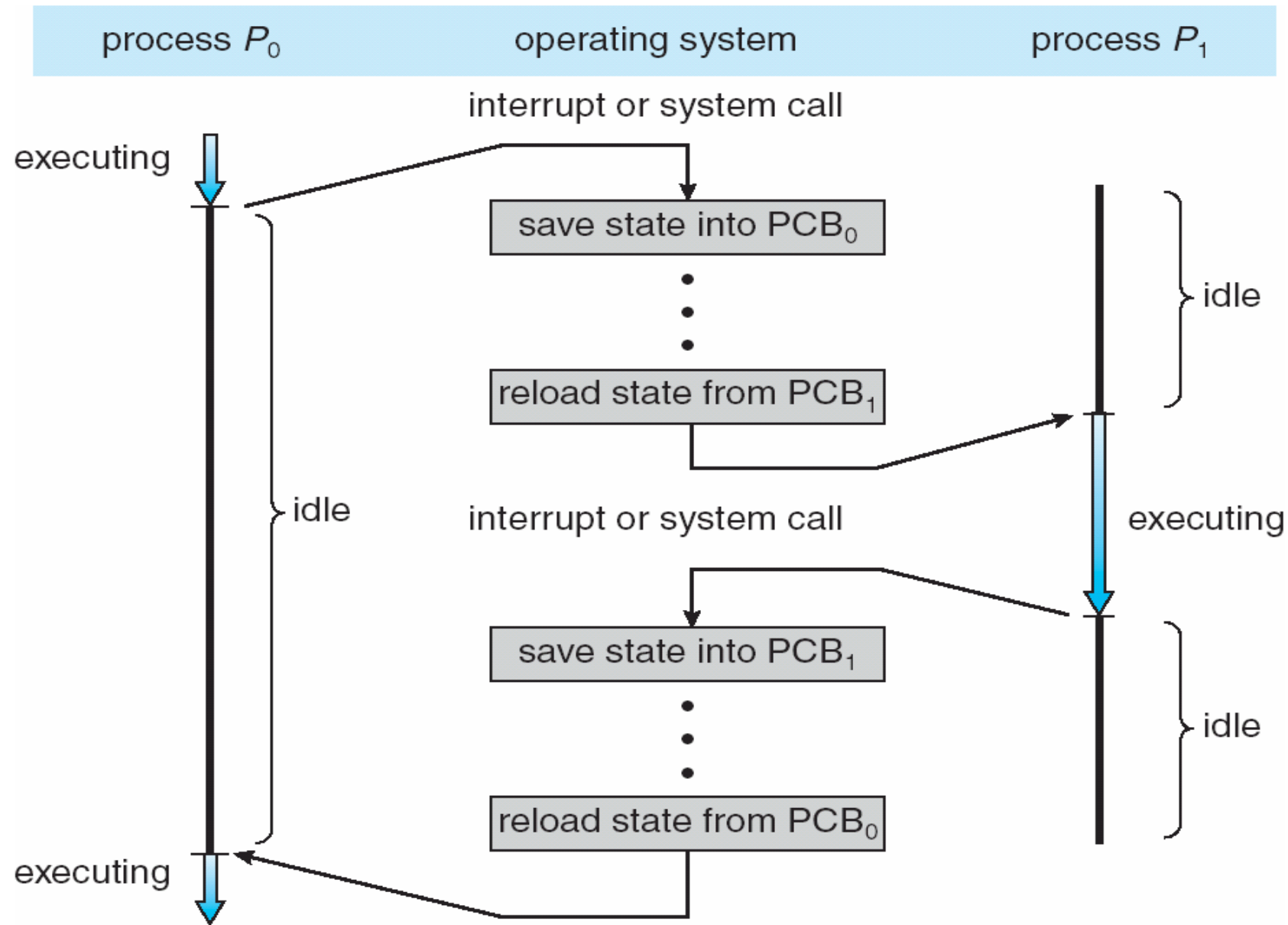

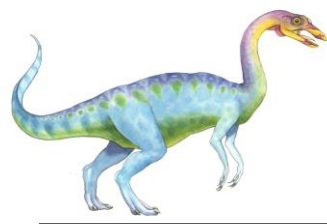

Process Scheduling

- Maximize CPU use, quickly switch processes onto CPU for time sharing
- **Process scheduler** selects among available processes for next execution on CPU
- Maintains **scheduling queues** of processes
 - **Job queue** – set of all processes in the system
 - **Ready queue** – set of all processes residing in main memory, ready and waiting to execute
 - **Device queues** – set of processes waiting for an I/O device
 - Processes migrate among the various queues





Process Representation in Linux

- Represented by the C structure `task_struct`

```
pid_t pid; /* process identifier */
long state; /* state of the process */
unsigned int time_slice /* scheduling information */
struct task_struct *parent; /* this process's parent */
struct list_head children; /* this process's children */
struct files_struct *files; /* list of open files */
struct mm_struct *mm; /* address space of this pro */
```

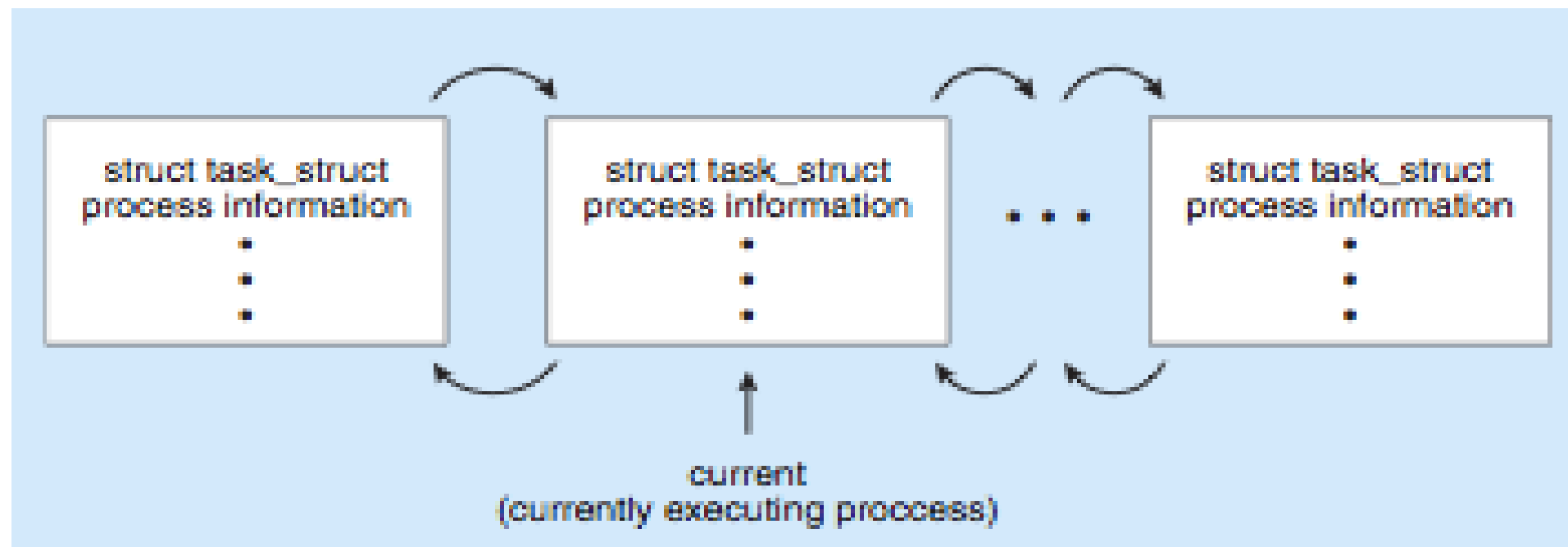



Ready Queue And Various I/O Device Queues

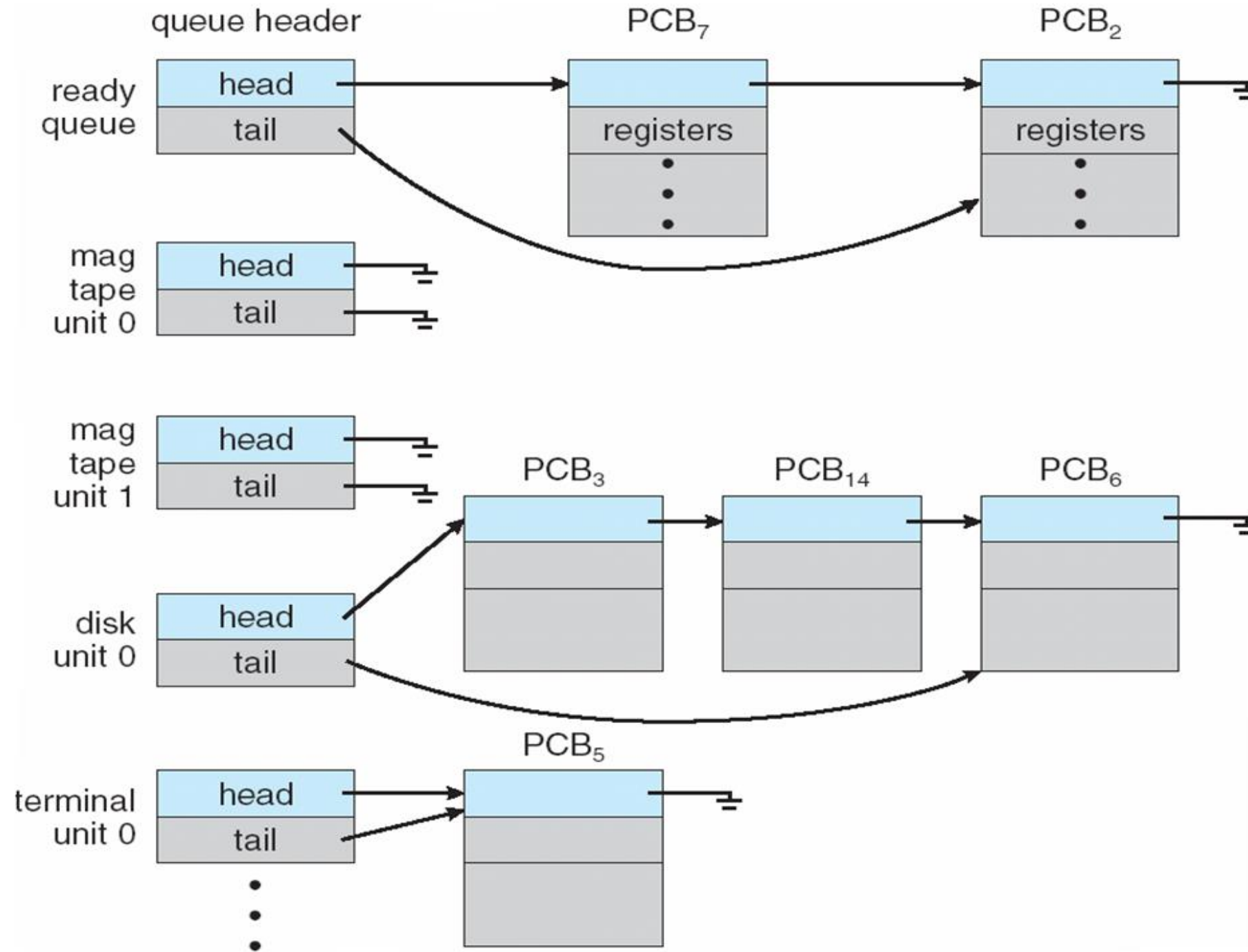



Representation of Process Scheduling

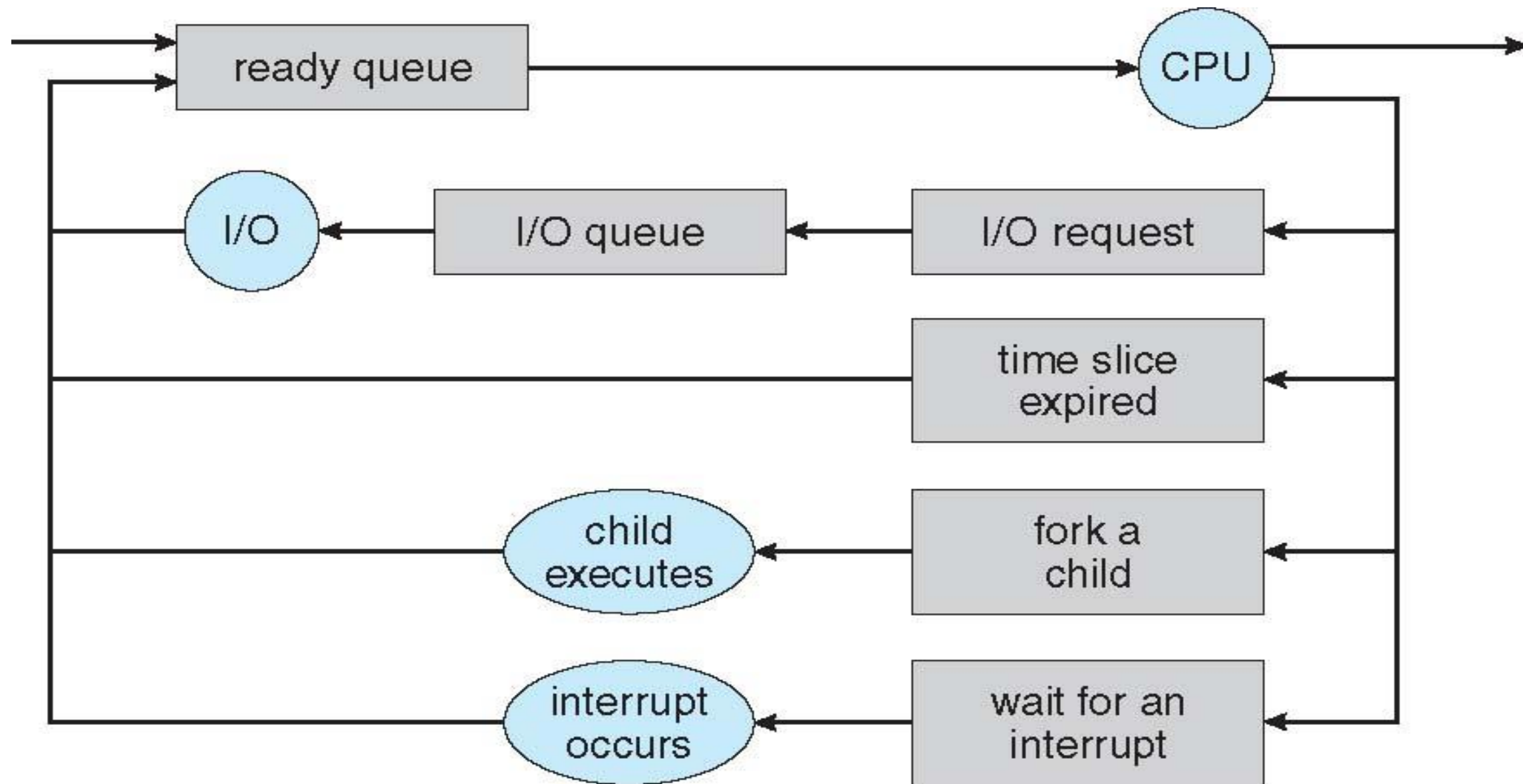

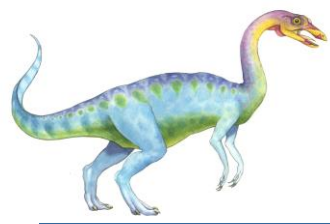

Schedulers

- **Long-term scheduler** (or job scheduler) – selects which processes should be brought into the ready queue
- **Short-term scheduler** (or CPU scheduler) – selects which process should be executed next and allocates CPU
 - Sometimes the only scheduler in a system



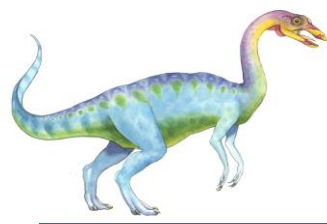

Schedulers (Cont.)

- Short-term scheduler is invoked very frequently (milliseconds) \Rightarrow (must be fast)
- Long-term scheduler is invoked very infrequently (seconds, minutes) \Rightarrow (may be slow)
- The long-term scheduler controls the *degree of multiprogramming*
- Processes can be described as either:
 - **I/O-bound process** – spends more time doing I/O than computations, many short CPU bursts
 - **CPU-bound process** – spends more time doing computations; few very long CPU bursts





Addition of Medium Term Scheduling

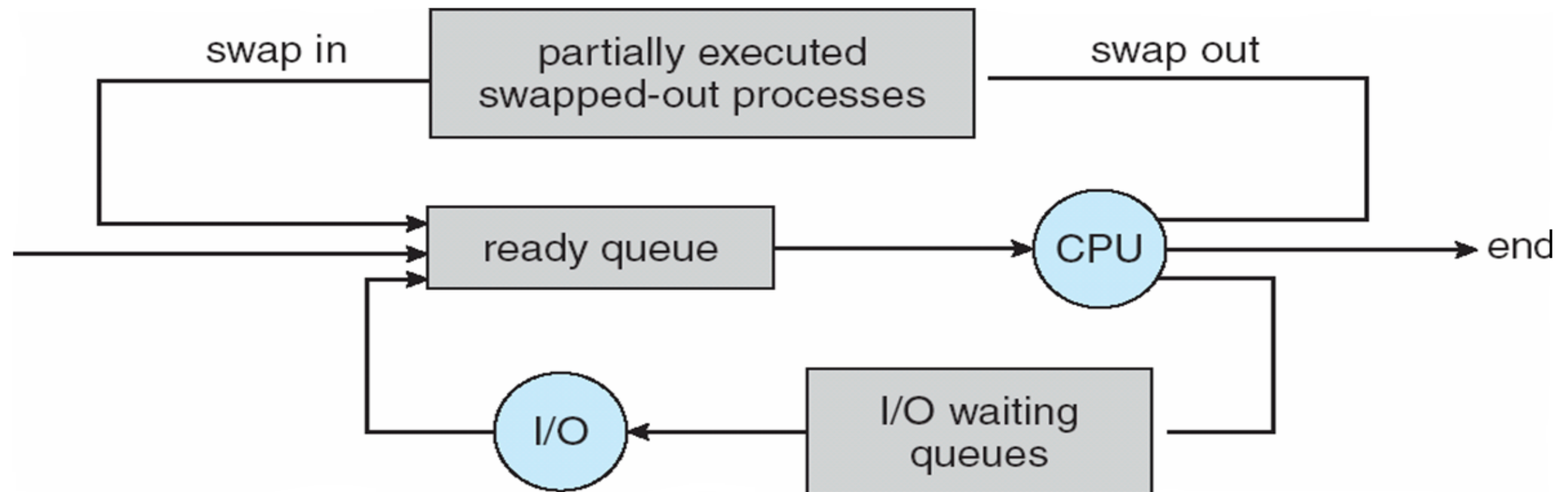

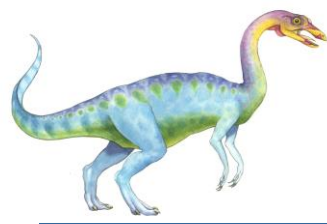

Context Switch

- When CPU switches to another process, the system must save the state of the old process and load the saved state for the new process via a **context switch**.
- **Context** of a process represented in the PCB
- Context-switch time is overhead; the system does no useful work while switching
 - The more complex the OS and the PCB -> longer the context switch
- Time dependent on hardware support
 - Some hardware provides multiple sets of registers per CPU -> multiple contexts loaded at once



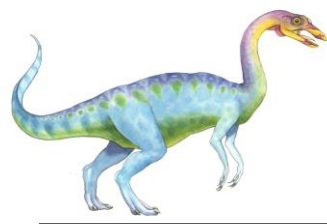

Process Creation

- **Parent** process create **children** processes, which, in turn create other processes, forming a tree of processes
- Generally, process identified and managed via a **process identifier (pid)**
- Resource sharing
 - Parent and children share all resources
 - Children share subset of parent' s resources
 - Parent and child share no resources
- Execution
 - Parent and children execute concurrently
 - Parent waits until children terminate





Process Creation (Cont.)

- Address space
 - Child duplicate of parent
 - Child has a program loaded into it

- UNIX examples
 - **fork** system call creates new process
 - **exec** system call used after a **fork** to replace the process' memory space with a new program





Process Creation

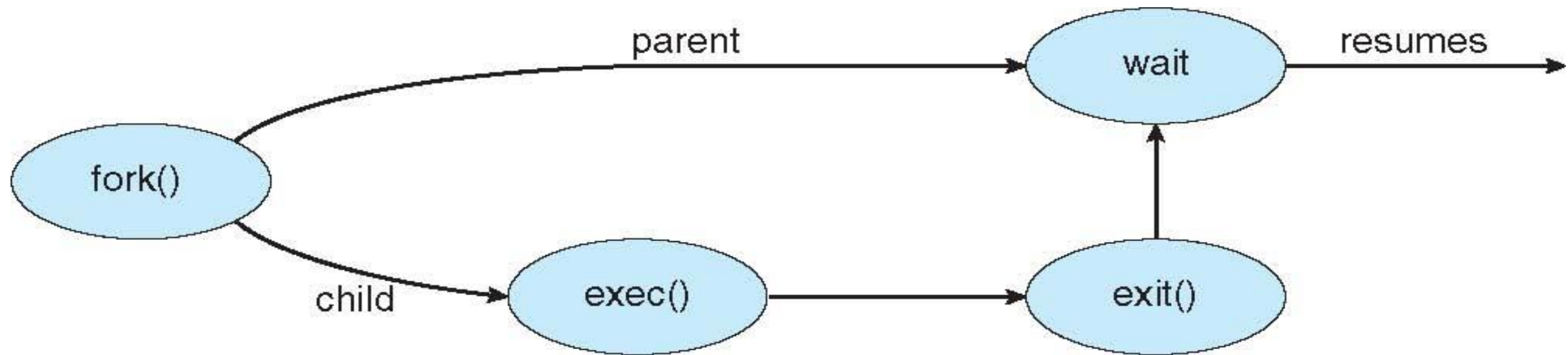



C Program Forking Separate Process

```
#include <sys/types.h>
#include <studio.h>
#include <unistd.h>
int main()
{
pid_t pid;
    /* fork another process */
    pid = fork();
    if (pid < 0) { /* error occurred */
        fprintf(stderr, "Fork Failed");
        return 1;
    }
    else if (pid == 0) { /* child process */
        execlp("/bin/ls", "ls", NULL);
    }
    else { /* parent process */
        /* parent will wait for the child */
        wait (NULL);
        printf ("Child Complete");
    }
    return 0;
}
```





A Tree of Processes on Solaris

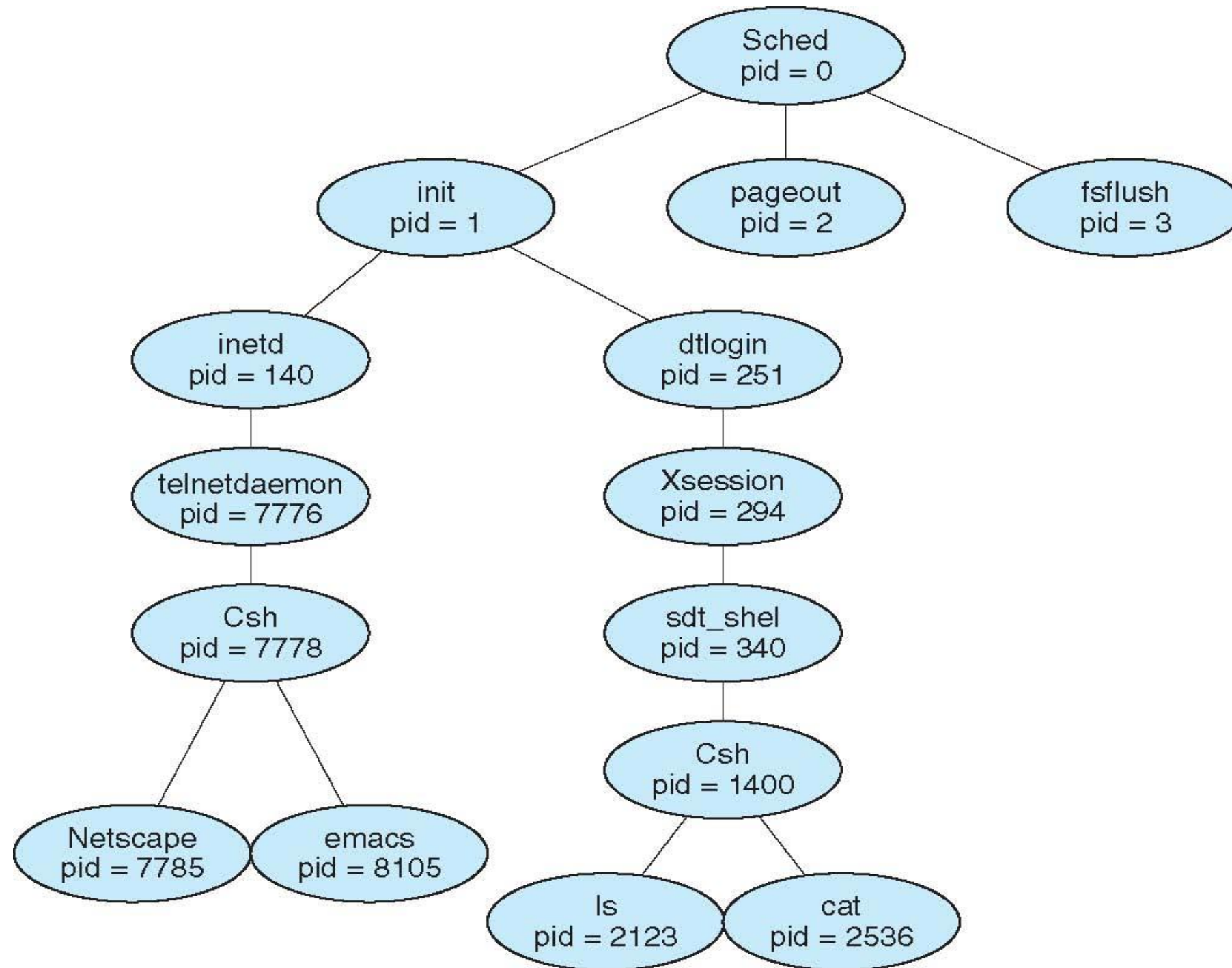



Process Termination

- Process executes last statement and asks the operating system to delete it (**exit**)
 - Output data from child to parent (via **wait**)
 - Process' resources are deallocated by operating system

- Parent may terminate execution of children processes (**abort**)
 - Child has exceeded allocated resources
 - Task assigned to child is no longer required
 - If parent is exiting
 - ▶ Some operating system do not allow child to continue if its parent terminates
 - All children terminated - **cascading termination**





Interprocess Communication

- Processes within a system may be **independent** or **cooperating**
- Cooperating process can affect or be affected by other processes, including sharing data
- Reasons for cooperating processes:
 - Information sharing
 - Computation speedup
 - Modularity
 - Convenience
- Cooperating processes need **interprocess communication (IPC)**
- Two models of IPC
 - Shared memory
 - Message passing





Communications Models

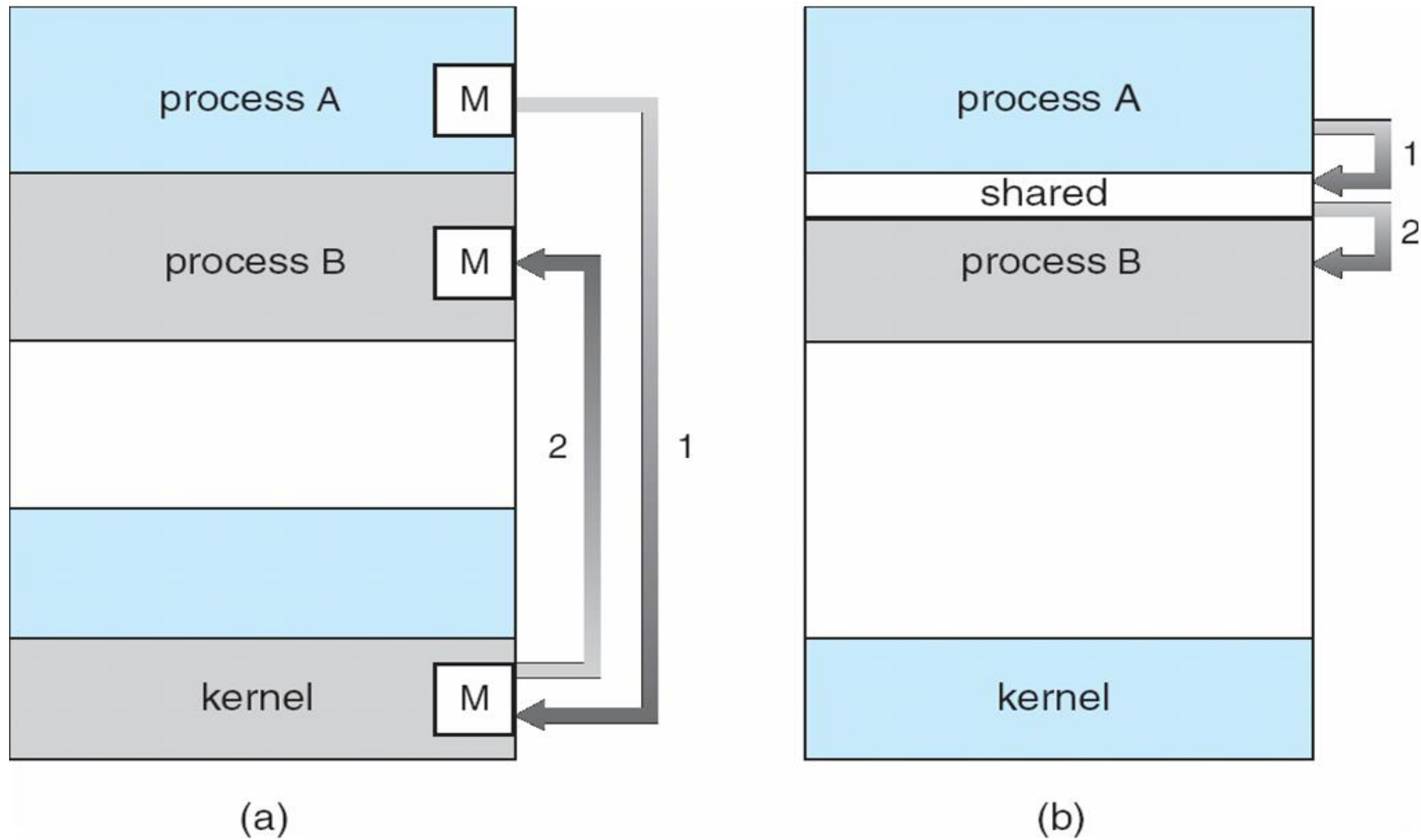

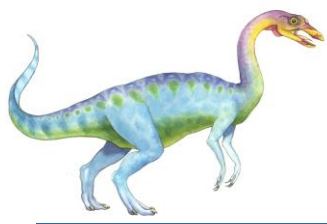

Cooperating Processes

- **Independent** process cannot affect or be affected by the execution of another process
- **Cooperating** process can affect or be affected by the execution of another process
- Advantages of process cooperation
 - Information sharing
 - Computation speed-up
 - Modularity
 - Convenience





Producer-Consumer Problem

- Paradigm for cooperating processes, *producer* process produces information that is consumed by a *consumer* process
 - *unbounded-buffer* places no practical limit on the size of the buffer
 - *bounded-buffer* assumes that there is a fixed buffer size





Bounded-Buffer – Shared-Memory Solution

- Shared data

```
#define BUFFER_SIZE 10  
typedef struct {  
    . . .  
} item;  
  
item buffer[BUFFER_SIZE];  
int in = 0;  
int out = 0;
```

- Solution is correct, but can only use BUFFER_SIZE-1 elements





Bounded-Buffer – Producer

```
while (true) {  
    /* Produce an item */  
    while (((in = (in + 1) % BUFFER SIZE count) == out)  
        ; /* do nothing -- no free buffers */  
    buffer[in] = item;  
    in = (in + 1) % BUFFER SIZE;  
}
```





Bounded Buffer – Consumer

```
while (true) {  
    while (in == out)  
        ; // do nothing -- nothing to consume  
  
    // remove an item from the buffer  
    item = buffer[out];  
    out = (out + 1) % BUFFER SIZE;  
    return item;  
}
```





Interprocess Communication – Message Passing

- Mechanism for processes to communicate and to synchronize their actions
- Message system – processes communicate with each other without resorting to shared variables
- IPC facility provides two operations:
 - **send**(*message*) – message size fixed or variable
 - **receive**(*message*)
- If P and Q wish to communicate, they need to:
 - establish a *communication link* between them
 - exchange messages via send/receive
- Implementation of communication link
 - physical (e.g., shared memory, hardware bus)
 - logical (e.g., logical properties)





Implementation Questions

- How are links established?
- Can a link be associated with more than two processes?
- How many links can there be between every pair of communicating processes?
- What is the capacity of a link?
- Is the size of a message that the link can accommodate fixed or variable?
- Is a link unidirectional or bi-directional?





Direct Communication

- Processes must name each other explicitly:
 - **send** ($P, message$) – send a message to process P
 - **receive**($Q, message$) – receive a message from process Q

- Properties of communication link
 - Links are established automatically
 - A link is associated with exactly one pair of communicating processes
 - Between each pair there exists exactly one link
 - The link may be unidirectional, but is usually bi-directional



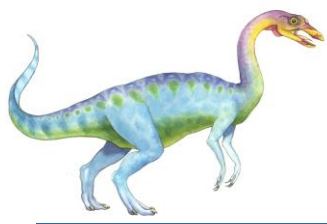

Indirect Communication

- Messages are directed and received from mailboxes (also referred to as ports)
 - Each mailbox has a unique id
 - Processes can communicate only if they share a mailbox

- Properties of communication link
 - Link established only if processes share a common mailbox
 - A link may be associated with many processes
 - Each pair of processes may share several communication links
 - Link may be unidirectional or bi-directional



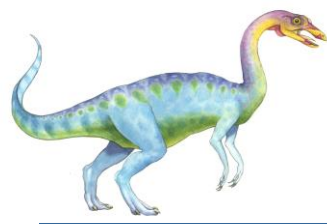

Indirect Communication

- Operations
 - create a new mailbox
 - send and receive messages through mailbox
 - destroy a mailbox

- Primitives are defined as:
 - send**(*A*, *message*) – send a message to mailbox *A*
 - receive**(*A*, *message*) – receive a message from mailbox *A*





Indirect Communication

- Mailbox sharing
 - P_1 , P_2 , and P_3 share mailbox A
 - P_1 sends; P_2 and P_3 receive
 - Who gets the message?

- Solutions
 - Allow a link to be associated with at most two processes
 - Allow only one process at a time to execute a receive operation
 - Allow the system to select arbitrarily the receiver. Sender is notified who the receiver was.



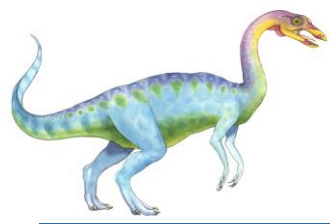

Synchronization

- Message passing may be either blocking or non-blocking

- **Blocking** is considered **synchronous**
 - **Blocking send** has the sender block until the message is received
 - **Blocking receive** has the receiver block until a message is available

- **Non-blocking** is considered **asynchronous**
 - **Non-blocking send** has the sender send the message and continue
 - **Non-blocking receive** has the receiver receive a valid message or null





Buffering

- Queue of messages attached to the link; implemented in one of three ways
 1. Zero capacity – 0 messages
Sender must wait for receiver (rendezvous)
 2. Bounded capacity – finite length of n messages
Sender must wait if link full
 3. Unbounded capacity – infinite length
Sender never waits





Examples of IPC Systems - POSIX

■ POSIX Shared Memory

- Process first creates shared memory segment

```
segment id = shmget(IPC_PRIVATE, size, S_IRUSR | S_IWUSR);
```

- Process wanting access to that shared memory must attach to it

```
shared memory = (char *) shmat(id, NULL, 0);
```

- Now the process could write to the shared memory

```
sprintf(shared memory, "Writing to shared memory");
```

- When done a process can detach the shared memory from its address space

```
shmdt(shared memory);
```





Examples of IPC Systems - Mach

- Mach communication is message based
 - Even system calls are messages
 - Each task gets two mailboxes at creation- Kernel and Notify
 - Only three system calls needed for message transfer
`msg_send()`, `msg_receive()`, `msg_rpc()`
 - Mailboxes needed for communication, created via
`port_allocate()`





Examples of IPC Systems – Windows XP

- Message-passing centric via **local procedure call (LPC)** facility
 - Only works between processes on the same system
 - Uses ports (like mailboxes) to establish and maintain communication channels
 - Communication works as follows:
 - ▶ The client opens a handle to the subsystem's connection port object.
 - ▶ The client sends a connection request.
 - ▶ The server creates two private communication ports and returns the handle to one of them to the client.
 - ▶ The client and server use the corresponding port handle to send messages or callbacks and to listen for replies.



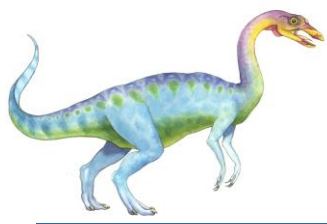

Local Procedure Calls in Windows XP

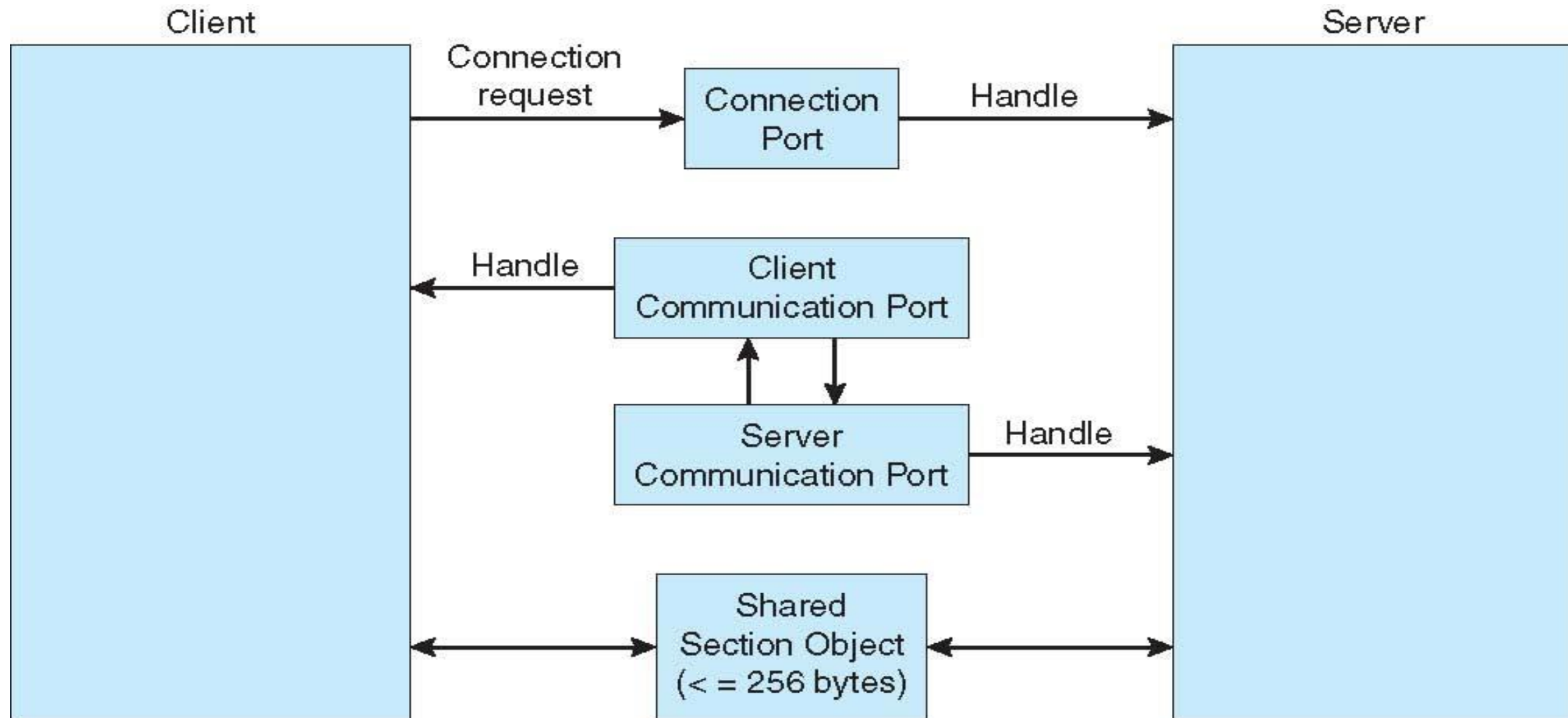



Communications in Client-Server Systems

- Sockets
- Remote Procedure Calls
- Pipes
- Remote Method Invocation (Java)





Sockets

- A **socket** is defined as an *endpoint for communication*
- Concatenation of IP address and port
- The socket **161.25.19.8:1625** refers to port **1625** on host **161.25.19.8**
- Communication consists between a pair of sockets





Socket Communication

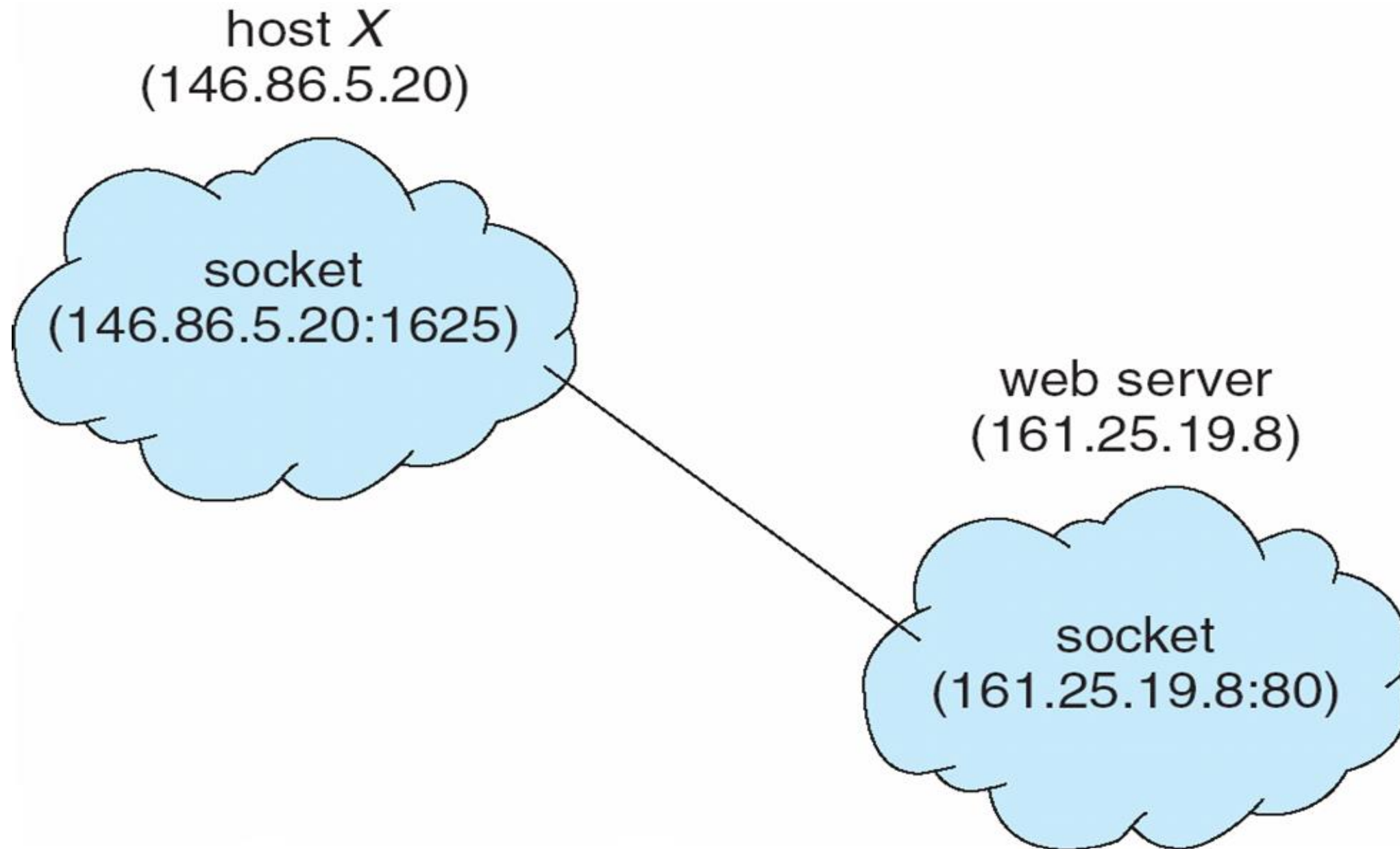



Remote Procedure Calls

- Remote procedure call (RPC) abstracts procedure calls between processes on networked systems
- **Stubs** – client-side proxy for the actual procedure on the server
- The client-side stub locates the server and *marshalls* the parameters
- The server-side stub receives this message, unpacks the marshalled parameters, and performs the procedure on the server





Execution of RPC

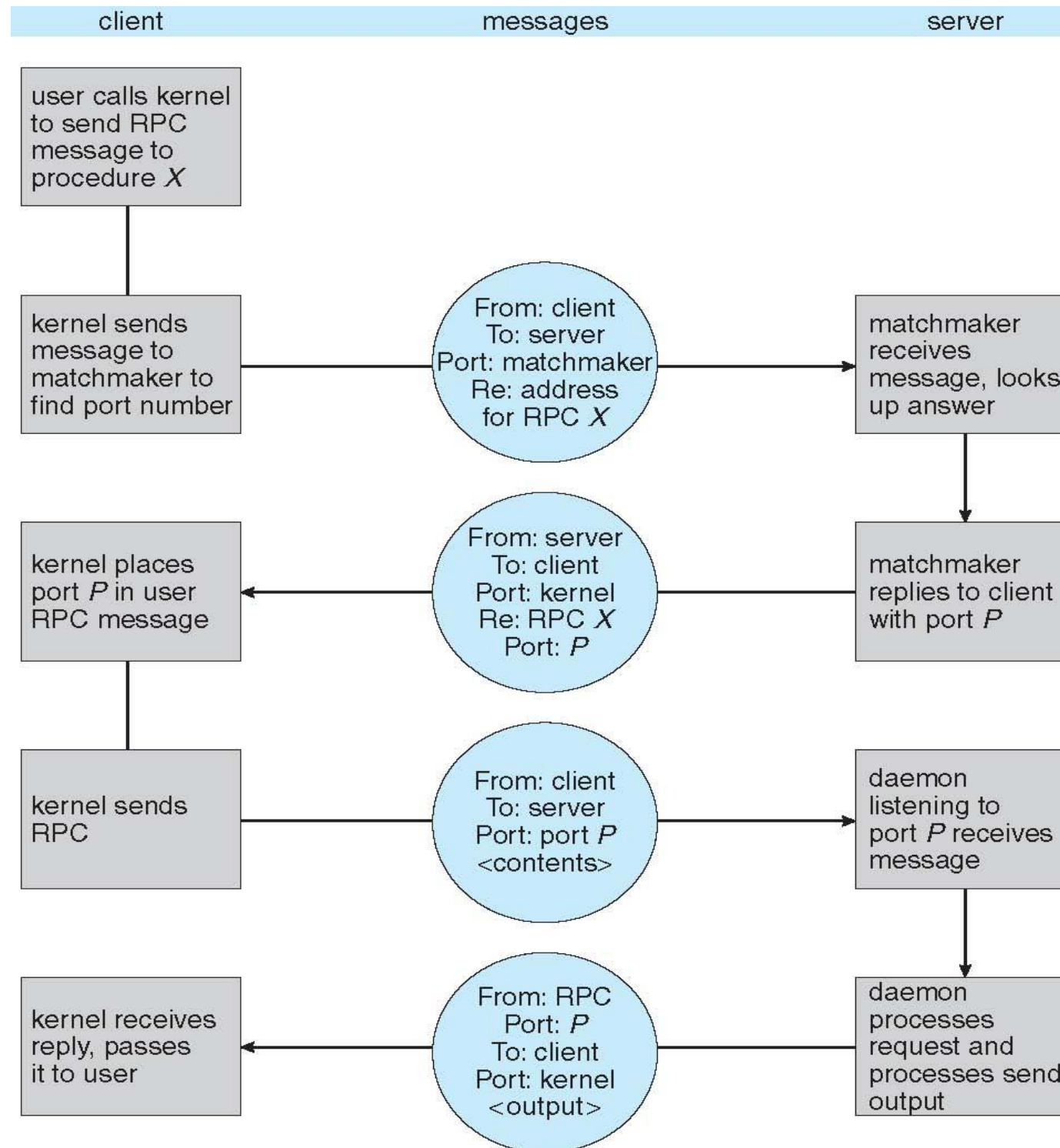



Pipes

- Acts as a conduit allowing two processes to communicate

- **Issues**
 - Is communication unidirectional or bidirectional?
 - In the case of two-way communication, is it half or full-duplex?
 - Must there exist a relationship (i.e. parent-child) between the communicating processes?
 - Can the pipes be used over a network?



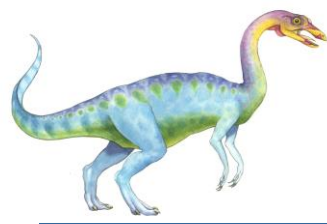

Ordinary Pipes

- **Ordinary Pipes** allow communication in standard producer-consumer style
- Producer writes to one end (the *write-end* of the pipe)
- Consumer reads from the other end (the *read-end* of the pipe)
- Ordinary pipes are therefore unidirectional
- Require parent-child relationship between communicating processes





Ordinary Pipes

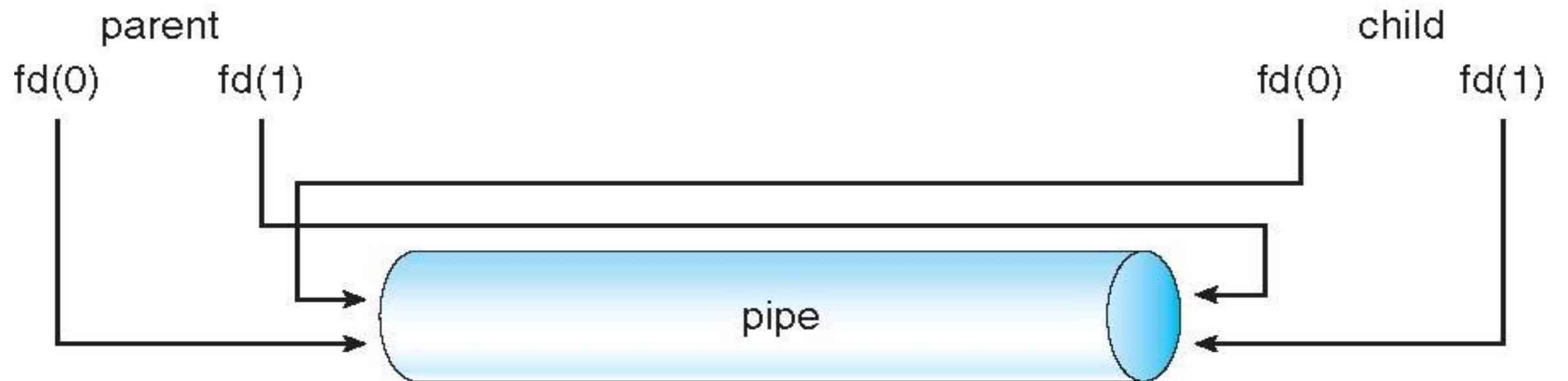

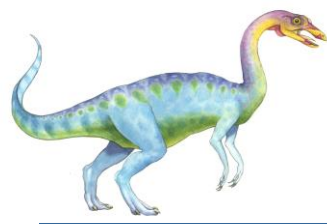

Named Pipes

- Named Pipes are more powerful than ordinary pipes
- Communication is bidirectional
- No parent-child relationship is necessary between the communicating processes
- Several processes can use the named pipe for communication
- Provided on both UNIX and Windows systems



End of Chapter 3

